

Chest Freezer
Solid Top Chest Freezer 59.5
" Long

ITEM # _____

MODEL # _____

NAME # _____

SIS # _____

AIA # _____



738231 (KCCF170WH)

Solid Top Chest Freezer 59.5
" Long

Short Form Specification

Item No. _____

Solid top chest freezer with foamed lid and soft closing mechanism to ensure gentle lid closure. Internal and external structure in white painted steel. Basket, vertical basket divider, NSF thermometer and lock included as standard. Defrost water drain with plug for easy cleaning.

R290 refrigerant gas for the lowest environmental impact (GWP=3).

The temperature range is -15° to 10°F.

ETL safety and sanitation listed for US and Canada.

Equipped with NEMA 5-15P plug.

Main Features

- Temperature range of -15 to +10 F°
- Hydrocarbon refrigerant gas R290 for the lowest environmental impact (GWP=3) - CFC and HCFC free.
- Low energy consumption
- Mechanical control panel with adjustable temperature
- Included as standard 1 NSF® certified temperature gauge and 1 basket (including one vertical divider) durable and reliable for safety in food storage
- Removable rubber bumper guards
- Bottom drain with plug for easy interior cleaning and defrost water discharge

Construction

- Foamed lid for best insulation and product robustness
- Soft closing lid mechanism
- Static condenser
- Exterior and Interior finish in white painted steel
- Locking lid and key protect the contents of the unit
- Mounted on heavy-duty casters, two locking to keep unit in place but allows position adjusting.

Optional Accessories

- Basket for Solid Top Chest Freezer PNC 882000
22.63x8.15x7.52 in. (575x207x191 mm)

APPROVAL: _____

Front

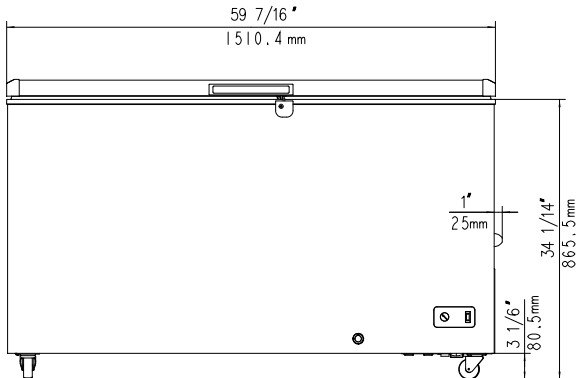

Side

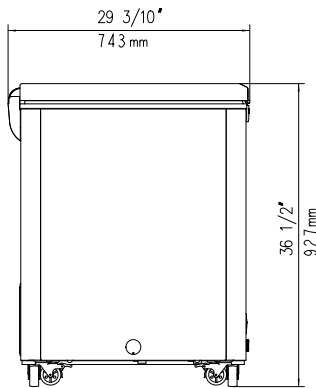

EI = Electrical connection

Top

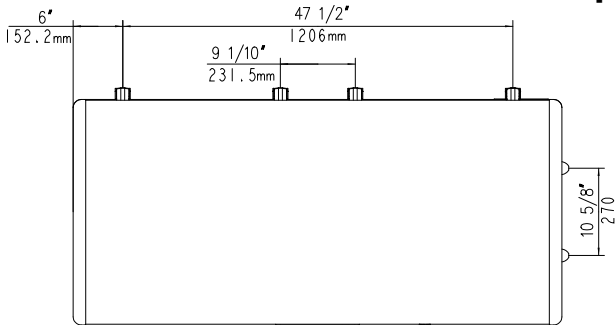

Electric

Supply voltage:

738231 (KCCF170WH) 115 V/1 ph/60 Hz

Electrical power, max:

0.2 kW

Plug type:

USA NEMA 1-15P

Capacity:

Gross capacity: 17.7 cu.feet

Key Information:

External dimensions, Width:	59 7/16" (1510 mm)
External dimensions, Depth:	29 5/16" (744.22 mm)
External dimensions, Height:	36 1/2" (927 mm)
Condenser type:	Static
Automatic Defrost Cooling System:	No
Compressor Horsepower:	1/5
Freezer baskets (Number/Type):	1 / Wire
Control	Mechanical
Warranty	1/5 Years
Net weight:	170 lbs (77 kg)
Shipping width:	30 1/2" (775 mm)
Shipping height:	42 1/64" (1067 mm)
Shipping weight:	205 lbs (93 kg)
Shipping volume:	46.22 ft ³ (1.31 m ³)

Refrigeration Data

Temperature display location:	Internal
Temperature range:	-15 to 10 °F
Refrigerant type:	R290



Chest Freezer
Solid Top Chest Freezer 59.5" Long

The company reserves the right to make modifications to the products without prior notice. All information correct at time of printing.